

LINEAR

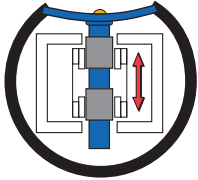

Linear Diaphragm Pumps

MODELS

LM 15
LM 22

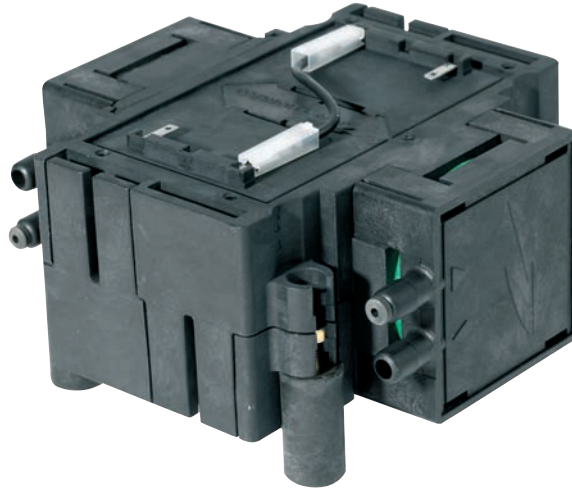

PRODUCT FEATURES

- Oil-less
- Maintenance free
- Long life
- Compact
- High flow
- Low power consumption

TYPICAL APPLICATIONS

- Medical
- Aeration
- Gas circulation
- Gas/particle analysis
- Energy technology



THOMAS
A Gardner Denver Product

Linear Diaphragm Pump LM 15 AC

Flow at 100 mbar

12,5 l/min

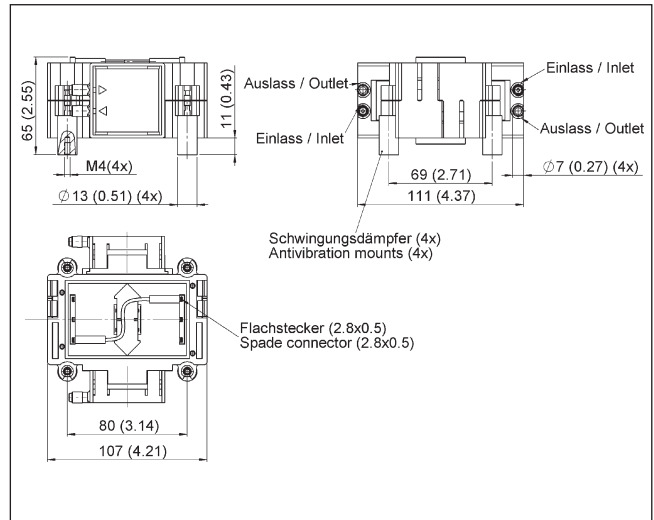

Pneumatic Data

Description	LM 15 230 V/50 Hz	LM 15 115 V/60 Hz
Part number	6440002	6440006
Flow at 100 mbar	12,5 l/min	12,5 l/min
Operating range	30% to 300 mbar	30% to 300 mbar

Electrical Data

Motor type	Linear drive	Linear drive
Nominal voltage	230 V/50 Hz	115 V/60 Hz
Consumption max.*	0,13 A/18 W	0,26 A/19 W
Protection class	IP 20	IP 20

General Data

Ambient temperature	10 to 50° C	10 to 50° C
Weight	0,95 kg	0,95 kg
Inlet/Outlet diameter	7 mm (4x)	7 mm (4x)

Wetted Parts

Pump chamber	Polypropylene	Polypropylene
Nozzle plate	Polypropylene	Polypropylene
Diaphragm	EPDM	EPDM
Valve gasket	EPDM	EPDM

* Between 0 and 100 mbar.

All listed values are measured at standard atmospheric conditions and parallel connection.

Flow curves

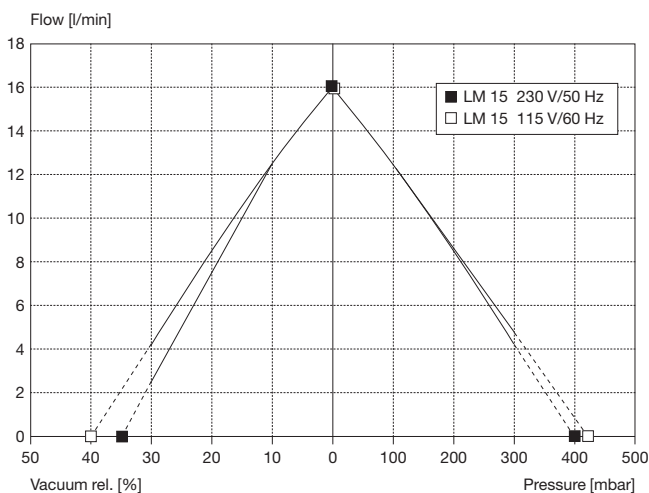

Option

644... Stock programme

Valve gasket: FPM (Viton)
 More antivibration mounts on request.
 Position of inlet/outlet in 90° steps possible.

The information presented in this material is based on technical data and test results of nominal units. It is believed to be accurate and reliable and is offered as an aid to help in the selection of Thomas products. It is the responsibility of the user to determine the suitability of the product for the intended use and the user assumes all risk and liability whatsoever in connection therewith. Thomas does not warrant, guarantee or assume any obligation of liability in connection with this information.

Linear Diaphragm Pump LM 15 DC

Flow at 100 mbar

11,5 l/min

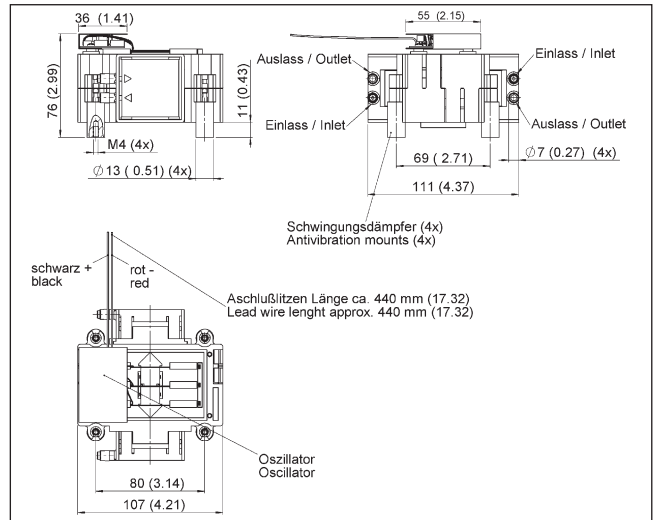

Pneumatic Data

Description	LM 15 12 V DC	LM 15 24 V DC
Part number	6440010	6440014
Flow at 100 mbar	11,5 l/min	11,5 l/min
Operating range	20% to 200 mbar	20% to 200 mbar

Electrical Data

Motor type	Linear drive	Linear drive
Nominal voltage	12 V DC	24 V DC
Consumption max.*	1,40 A/17 W	0,70 A/17 W
Protection class	IP 20	IP 20

General Data

Ambient temperature	10 to 50° C	10 to 50° C
Weight	0,95 kg	0,95 kg
Inlet/Outlet diameter	7 mm (4x)	7 mm (4x)

Wetted Parts

Pump chamber	Polypropylene	Polypropylene
Nozzle plate	Polypropylene	Polypropylene
Diaphragm	EPDM	EPDM
Valve gasket	EPDM	EPDM

* Between 0 and 100 mbar.

All listed values are measured at standard atmospheric conditions and parallel connection.

Pumps include oscillator part number: 8807 (standard).

Flow curves

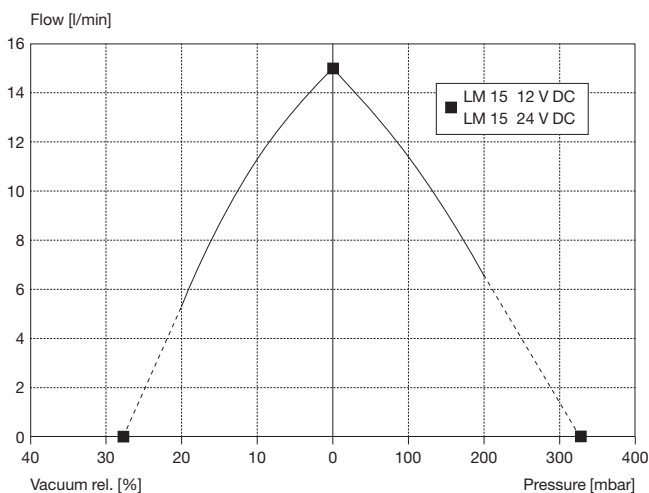

Option

- Valve gasket: FPM (Viton)
- More antivibration mounts on request.
- Position of inlet/outlet in 90° steps possible.

The information presented in this material is based on technical data and test results of nominal units. It is believed to be accurate and reliable and is offered as an aid to help in the selection of Thomas products. It is the responsibility of the user to determine the suitability of the product for the intended use and the user assumes all risk and liability whatsoever in connection therewith. Thomas does not warrant, guarantee or assume any obligation or liability in connection with this information.

Linear Diaphragm Pump LM 22 AC

Flow at 100 mbar

16 l/min

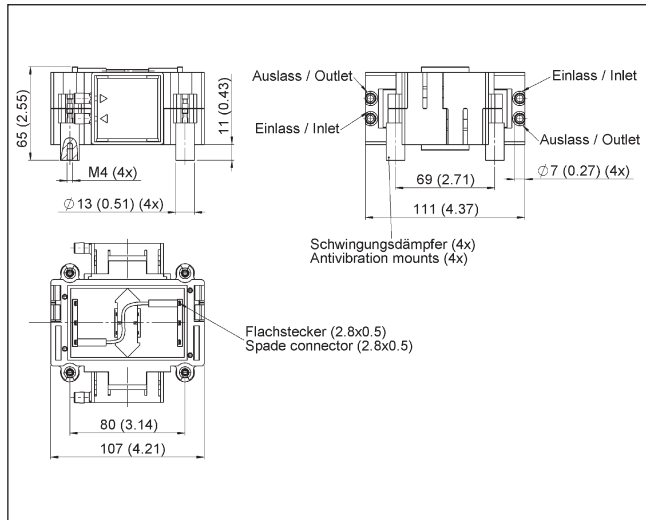

Pneumatic Data

Description	LM 22 230 V/50 Hz	LM 22 115 V/60 Hz
Part number	6540002	6540006
Flow at 100 mbar	16 l/min	16 l/min
Operating pressure range	50 to 250 mbar	50 to 250 mbar
Operating vacuum range	5% to 25%	5% to 25%

Electrical Data

Motor type	Linear drive	Linear drive
Nominal voltage	230 V/50 Hz	115 V/60 Hz
Consumption max.*	0,10 A/18 W	0,30 A/20 W
Protection class	IP 20	IP 20

General Data

Ambient temperature	10 to 50° C	10 to 50° C
Weight	0,95 kg	0,95 kg
Inlet/Outlet diameter	7 mm (4x)	7 mm (4x)

Wetted Parts

Pump chamber	Polypropylene	Polypropylene
Nozzle plate	Polypropylene	Polypropylene
Diaphragm	EPDM	EPDM
Valve gasket	EPDM	EPDM

* Between 0 and 100 mbar.

All listed values are measured at standard atmospheric conditions and parallel connection.

Flow curves

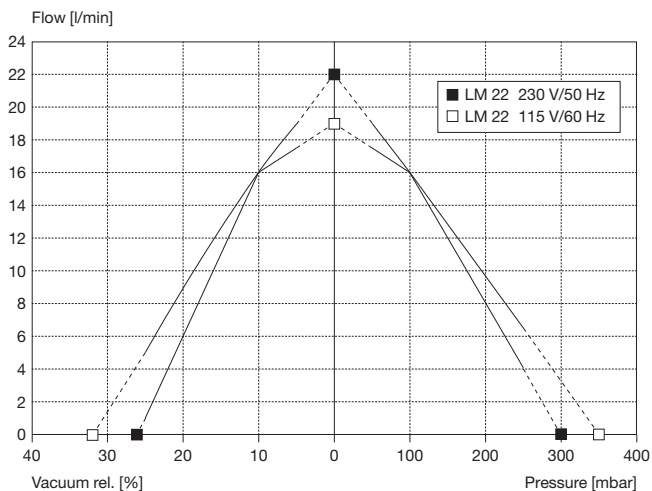

Option

654... Stock programme

Valve gasket: FPM (Viton)
 More antivibration mounts on request.
 Position of inlet/outlet in 90° steps possible.

The information presented in this material is based on technical data and test results of nominal units. It is believed to be accurate and reliable and is offered as an aid to help in the selection of Thomas products. It is the responsibility of the user to determine the suitability of the product for the intended use and the user assumes all risk and liability whatsoever in connection therewith. Thomas does not warrant, guarantee or assume any obligation or liability in connection with this information.

THOMAS
 A Gardner Denver Product

Linear Diaphragm Pump LM 22 DC

Flow at 100 mbar

15 l/min

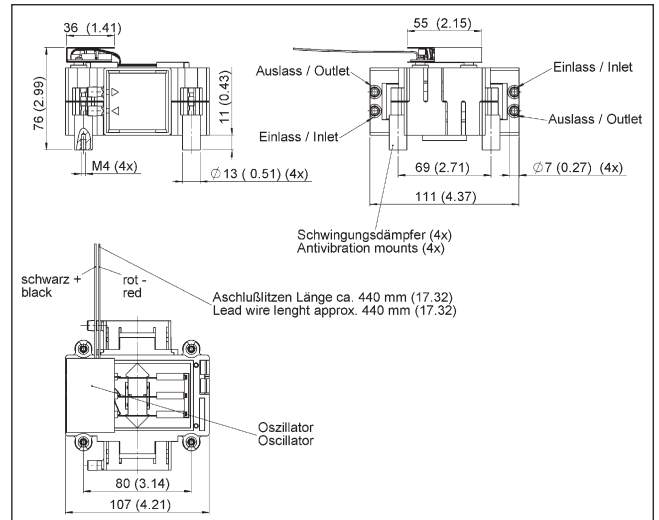

Pneumatic Data

Description	LM 22 12 V DC	LM 22 24 V DC
Part number	6540010	6540014
Flow at 100 mbar	15 l/min	15 l/min
Operating range	20% to 200 mbar	20% to 200 mbar

Electrical Data

Motor type	Linear drive	Linear drive
Nominal voltage	12 V DC	24 V DC
Consumption max.*	1,60 A/18 W	0,80 A/18 W
Protection class	IP 20	IP 20

General Data

Ambient temperature	10 to 50° C	10 to 50° C
Weight	0,95 kg	0,95 kg
Inlet/Outlet diameter	7 mm (4x)	7 mm (4x)

Wetted Parts

Pump chamber	Polypropylene	Polypropylene
Nozzle plate	Polypropylene	Polypropylene
Diaphragm	EPDM	EPDM
Valve gasket	EPDM	EPDM

* Between 0 and 100 mbar.

All listed values are measured at standard atmospheric conditions and parallel connection.

Pumps include oscillator part number: 8807 (standard).

Flow curves

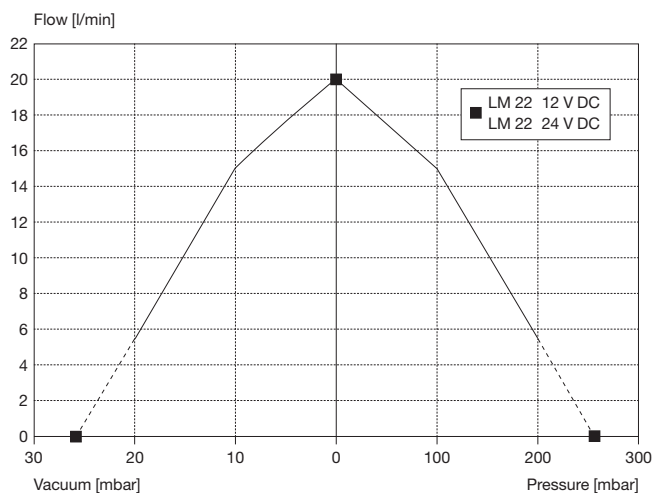

Option

Valve gasket: FPM (Viton)
More antivibration mounts on request.
Position of inlet/outlet in 90° steps possible.

The information presented in this material is based on technical data and test results of nominal units. It is believed to be accurate and reliable and is offered as an aid to help in the selection of Thomas products. It is the responsibility of the user to determine the suitability of the product for the intended use and the user assumes all risk and liability whatsoever in connection therewith. Thomas does not warrant, guarantee or assume any obligation or liability in connection with this information.

THOMAS
A Gardner Denver Product



Printed in Germany.
Art.-Nr.: 17000096 11/2010
ClimatePartner 
printed climate-neutrally

Gardner Denver Thomas GmbH
Benzstraße 28 · Gewerbegebiet Nord · D-82178 Puchheim
Phone: +49 89 80900-0 · Fax: +49 89 808368
e-Mail: thomas.de@gardnerdenver.com · <http://www.gd-thomas.com>