

DIAPHRAGM



Miniature Diaphragm Pumps

MODELS

2002
3003
3013
5002

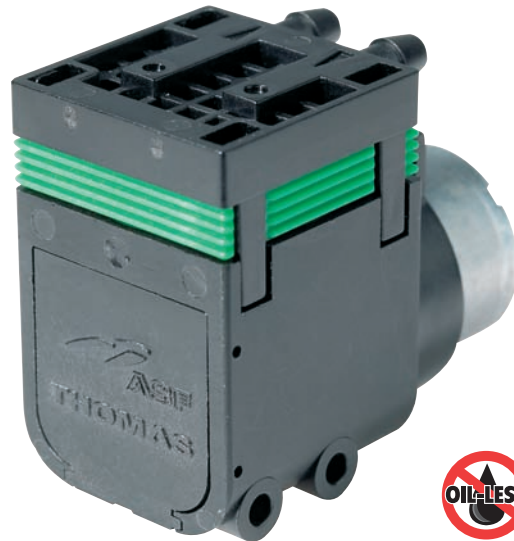

FEATURES

- Oil-less
- Maintenance free
- Balanced for smooth low vibration operation
- Low noise level
- Small
- Light weight
- High efficiency

TYPICAL APPLICATIONS

- Patient monitoring
- Anaesthetic control
- Gas detection devices
- Personal protection devices
- Flue gas measurement
- Pipetting devices



THOMAS
A Gardner Denver Product

Diaphragm Pump 2002 VD DC

Flow	380 ml/min
Max. pressure	400 mbar
Max. vacuum	40%

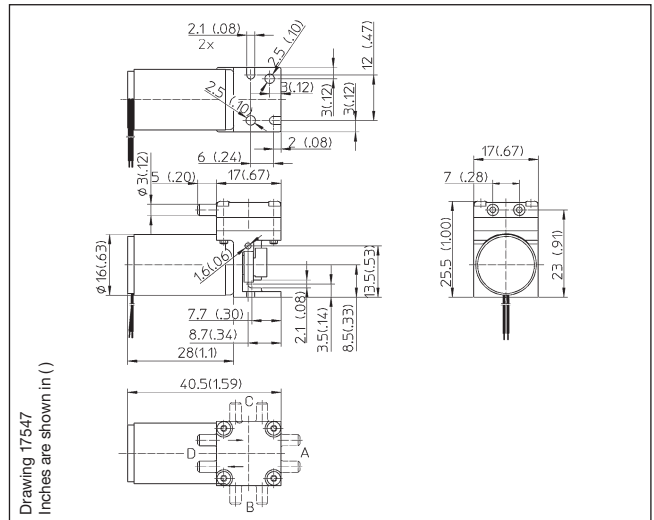

Pneumatic Data

Description	2002VD/0,5/E/DC	
Part number	3,5 V	20020301 (2 to 3,8 V)
	4,5 V	20020304 (3,5 to 7 V)
	6,0 V	20020307 (5 to 10 V)
Max. flow	380 ml/min	
Max. intermittent duty	380 to 400 mbar	
Max. continuous pressure	150 mbar	
Max. restart pressure	150 mbar	
Max. vacuum	36 to 40%	
Max. restart vacuum	15%	

Electrical Data

Motor type	Ironless core DC
Rated power	2 to 3,8 V/48 to 53 mA 3,5 to 7 V/32 to 37 mA 5 to 10 V/23 to 25 mA
Protection class	IP00
Bearing type	Sleeve bearing

General Data

Ambient temperature	10 to 50 °C
Media temperature	10 to 50 °C
Weight	32 g
Port direction	D

Wetted Parts

Pump head	Phenol resin	Options
Diaphragm, valves	EPDM	FPM (Viton®), Silicone

Noise suppression for the purpose of guideline 89/336 EWG electromagnetic tolerance.

Flow Curves

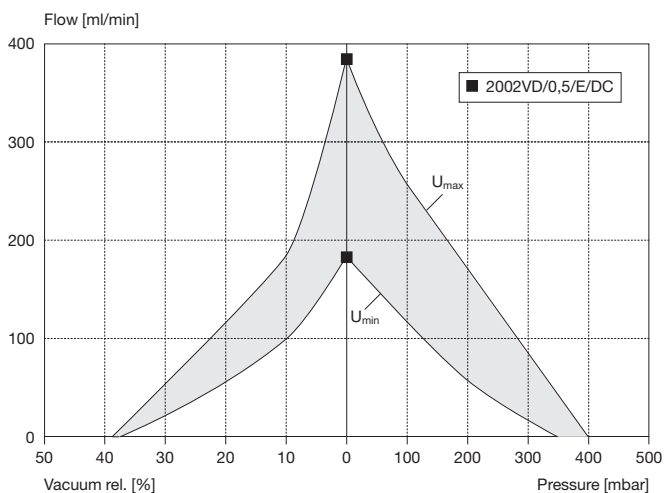

Options:

Bearing type Ball bearing

Model key:

2002... Stock programme

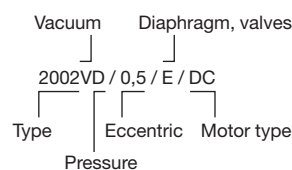

The information presented in this material is based on technical data and test results of nominal units. It is believed to be accurate and reliable and is offered as an aid to help in the selection of Thomas products. It is the responsibility of the user to determine the suitability of the product for the intended use and the user assumes all risk and liability whatsoever in connection therewith. Thomas does not warrant, guarantee or assume any obligation or liability in connection with this information.

Diaphragm Pump 2002 VD LC

Flow	500 ml/min
Max. pressure	400 mbar
Max. vacuum	40%

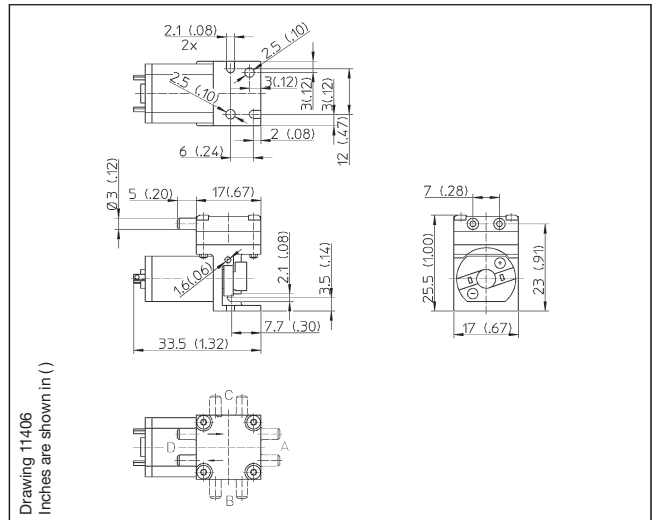

Pneumatic Data	
Description	2002VD/0,5/E/LC
Part number	3,5 V 20020215 (3,5 to 5 V)
Max. flow	500 ml/min
Max. intermittent duty	380 to 400 mbar
Max. continuous pressure	150 mbar
Max. restart pressure	150 mbar
Max. vacuum	36 to 40%
Max. restart vacuum	15%

Electrical Data	
Motor type	Permanent magnet
Rated power	3,5 to 5 V/90 mA
Protection class	IP00
Bearing type	Sleeve bearing

General Data	
Ambient temperature	10 to 50 °C
Media temperature	10 to 50 °C
Weight	17 g
Port direction	D

Wetted Parts	Options
Pump head	Phenol resin
Diaphragm, valves	EPDM
	FPM (Viton®), Silicone

Flow Curves

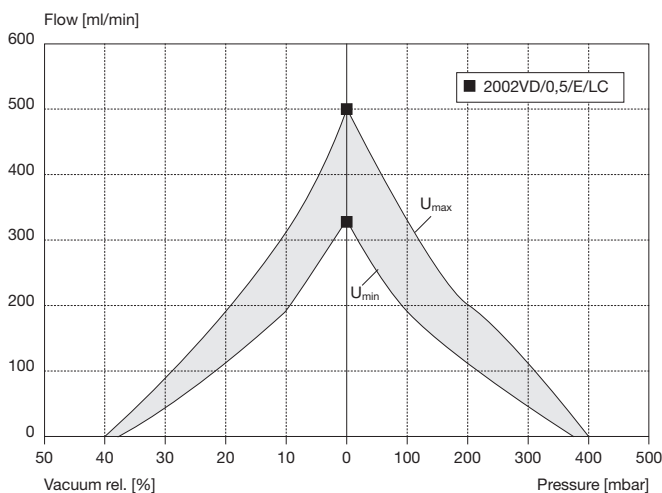

Model key:

2002... Stock programme

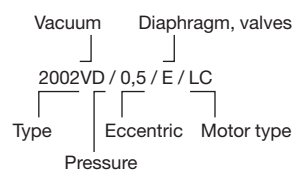

The information presented in this material is based on technical data and test results of nominal units. It is believed to be accurate and reliable and is offered as an aid to help in the selection of Thomas products. It is the responsibility of the user to determine the suitability of the product for the intended use and the user assumes all risk and liability whatsoever in connection therewith. Thomas does not warrant, guarantee or assume any obligation or liability in connection with this information.

Diaphragm Pump 2002 VD BLDC

Flow	800 ml/min
Max. pressure	600 mbar
Max. vacuum	52%

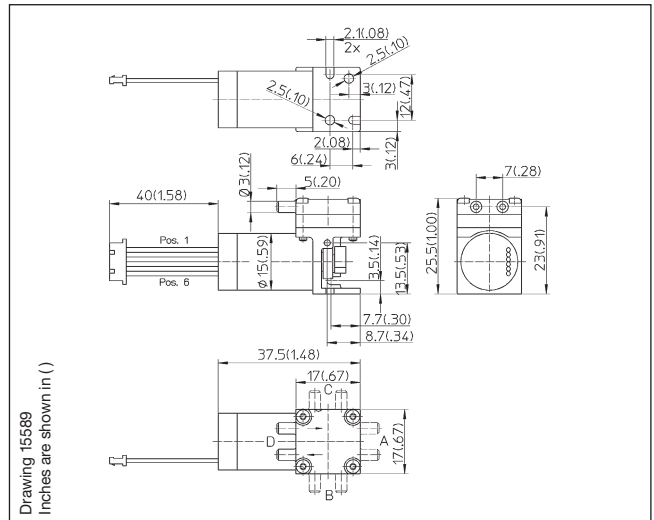
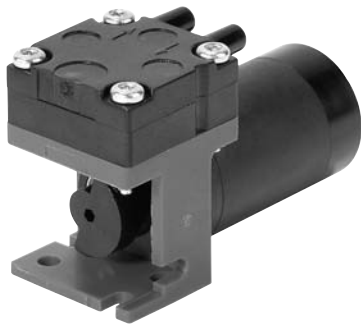

Pneumatic Data

Description	2002VD/0,7/E/BLDC
Part number	20020434
Max. flow	800 ml/min
Max. intermittend duty	550 to 600 mbar
Max. continuous pressure	150 mbar
Max. restart pressure	600 mbar
Max. vacuum	50% to 52%
Max. restart vacuum	52%

Electrical Data

Motor type	Brushless DC
Power consumption	0,8 W
Protection class (Motor)	IP40
Drive electronic	integrated
Bearing type	Ball bearing
Connector type:	Molex 51021-0600 / Terminal 50058-8100
Wiring diagramm:	

PIN 1	Vp	red	Electronics supply	5...18VDC
2	Vmot	black	Motor supply	5...18VDC (min. 4VDC higher than input voltage on PIN 4)
3	GND	black	Ground	
4	Vnsoll	black	Speed control	1...4VDC
5	DIR	black	Direction of rotation:	open: CW / ground: CCW
6	FG	black	Signal / 3 impulses per rotation	

General Data

Ambient temperature	10 to 50 °C
Media temperature	10 to 50 °C
Weight	22 g

Wetted Parts

Pump head	Phenol resin
Diaphragm, valves	EPDM

Options

FPM (Viton®), Silicone

Flow Curves

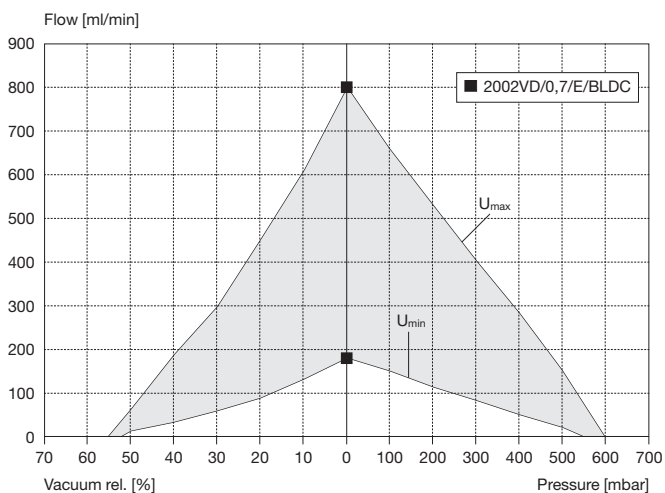

Model key:

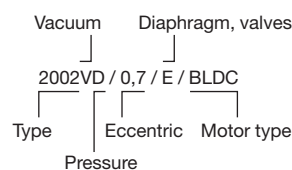

The information presented in this material is based on technical data and test results of nominal units. It is believed to be accurate and reliable and is offered as an aid to help in the selection of Thomas products. It is the responsibility of the user to determine the suitability of the product for the intended use and the user assumes all risk and liability whatsoever in connection therewith. Thomas does not warrant, guarantee or assume any obligation or liability in connection with this information.

Diaphragm Pump 3003 VD DC

Flow	1000 ml/min
Max. pressure	650 mbar
Max. vacuum	38%

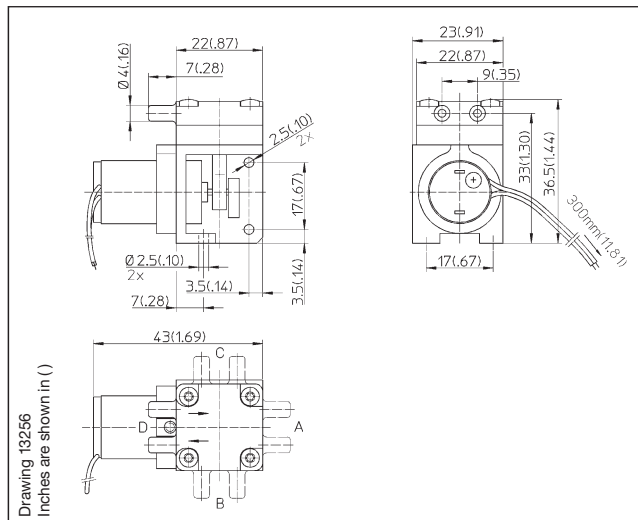

Pneumatic Data

Description	3003VD/0,7/E/DC	3003VD/0,7/E/DC	3003VD/0,7/E/DC
Part number	4,5 V 6,0 V 12,0 V	30030506	30030511
			30030509
Max. flow	850 ml/min	850 ml/min	1000 ml/min
Max. intermittent duty	650 mbar	650 mbar	650 mbar
Max. continuous pressure	200 mbar	200 mbar	200 mbar
Max. restart pressure	200 mbar	200 mbar	200 mbar
Max. vacuum	38%	38%	38%
Max. restart vacuum	20%	20%	20%

Electrical Data

Motor type	Ironless core DC	Ironless core DC	Ironless core DC
Rated power	4,5 V/105 mA	6 V/80 mA	12 V/66 mA
Protection class	IP00	IP00	IP00
Bearing type	Sleeve bearing	Ball bearing	Sleeve bearing

General Data

Ambient temperature	10 to 50 °C	10 to 50 °C	10 to 50 °C
Media temperature	10 to 50 °C	10 to 50 °C	10 to 50 °C
Weight	40 g	40 g	40 g
Port direction	D	D	D

Wetted Parts

Pump head	Phenol resin
Diaphragm plate	Polyamid
Diaphragm, valves	EPDM
Diaphragm screw	V2A

Options

FPM (Viton®), Silicone

Flow Curves

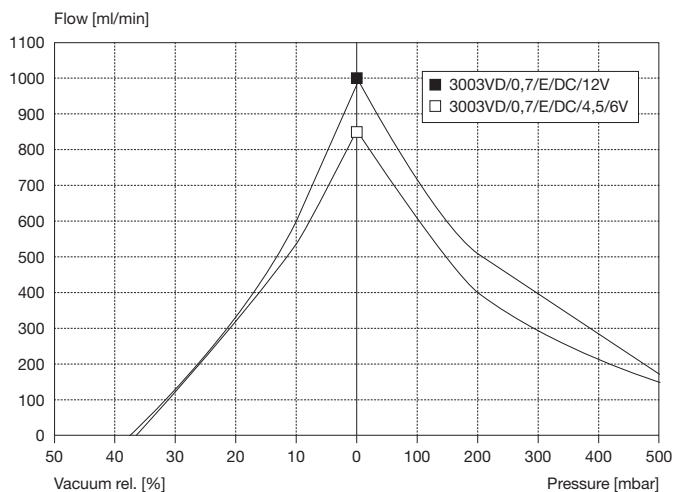

Noise suppression for the purpose of guideline 89/336 EWG electromagnetic tolerance.

Model key:

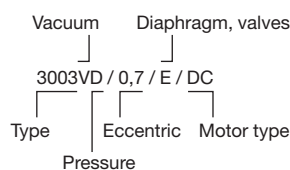

The information presented in this material is based on technical data and test results of nominal units. It is believed to be accurate and reliable and is offered as an aid to help in the selection of Thomas products. It is the responsibility of the user to determine the suitability of the product for the intended use and the user assumes all risk and liability whatsoever in connection therewith. Thomas does not warrant, guarantee or assume any obligation or liability in connection with this information.

Diaphragm Pump 3003 VD BLDC

Flow	700 ml/min
Max. pressure	1000 mbar
Max. vacuum	48%

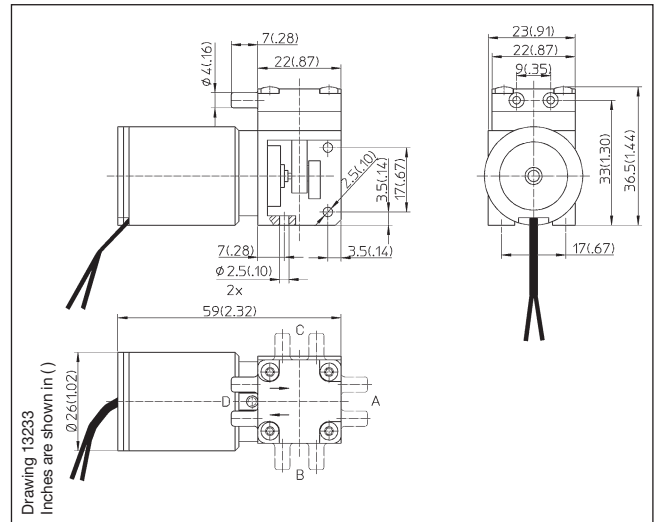

Pneumatic Data

Description		3003VD/0,9/E/BLDC
Part number	6 V	30030512
Max. flow		700 ml/min
Max. intermittent duty		1000 mbar
Max. continuous pressure		300 mbar
Max. restart pressure		700 mbar
Max. vacuum		48%
Max. restart vacuum		48%

Electrical Data

Motor type	Brushless DC
Rated power	6 V/180 mA
Protection class	IP00
Drive electronic	integrated
Bearing type	Ball bearing

General Data

Ambient temperature	10 to 50 °C
Media temperature	10 to 50 °C
Weight	95 g
Port direction	D

Wetted Parts Options

Pump head	Phenol resin	
Diaphragm plate	Polyamid	
Diaphragm, valves	EPDM	FPM (Viton®), Silicone
Diaphragm screw	V2A	

Flow Curves

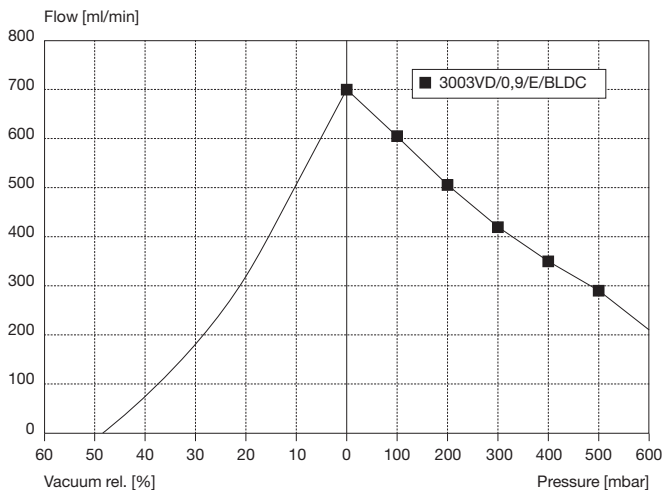

Model key:

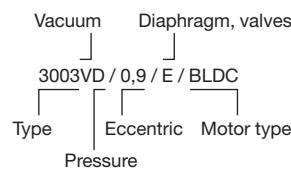

The information presented in this material is based on technical data and test results of nominal units. It is believed to be accurate and reliable and is offered as an aid to help in the selection of Thomas products. It is the responsibility of the user to determine the suitability of the product for the intended use and the user assumes all risk and liability whatsoever in connection therewith. Thomas does not warrant, guarantee or assume any obligation or liability in connection with this information.

Diaphragm Pump 3013 VD DC

Flow	1,2 l/min
Max. pressure	450 mbar
Max. vacuum	40%

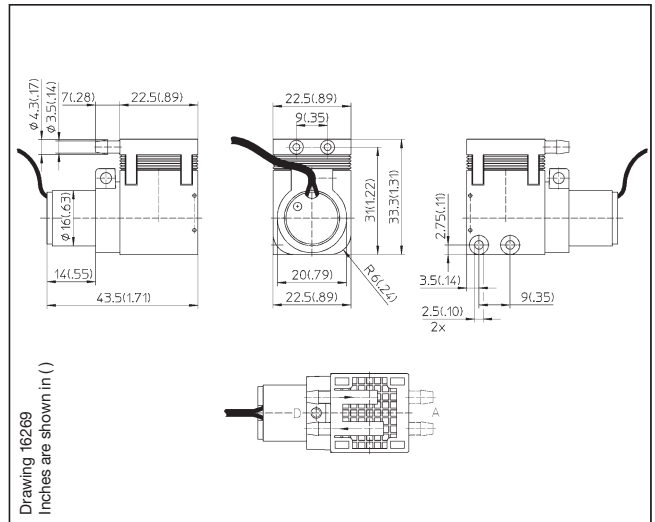

Pneumatic Data

Description	3013VD/0,7/E/DC	3013VD/0,7/E/DC	3013VD/0,7/E/DC
Part number	4,5 V 6,0 V 12,0 V 30130007	30130224	30130006
Max. flow	0,9 l/min	0,85 l/min	1,2 l/min
Max. intermittent duty	450 mbar	450 mbar	450 mbar
Max. continuous pressure	200 mbar	200 mbar	200 mbar
Max. restart pressure	200 mbar	200 mbar	200 mbar
Max. vacuum	40%	40%	40%
Max. restart vacuum	20%	20%	20%

Electrical Data

Motor type	Ironless core DC	Ironless core DC	Ironless core DC
Rated power	90 mA	40 mA	40 mA
Protection class	IP00	IP00	IP00
Bearing type	Sleeve bearing	Ball bearing	Sleeve bearing

General Data

Ambient temperature	10 to 40 °C	10 to 40 °C	10 to 40 °C
Media temperature	10 to 40 °C	10 to 40 °C	10 to 40 °C
Weight	32 g	32 g	32 g
Port direction	D	D	D

Wetted Parts

Wetted Parts	Options
Pump head	Polycarbonate
Diaphragm	EPDM
Valve/gasket	EPDM

Options

Ryton®
FPM (Viton®)
FPM (Viton®)

Flow Curves

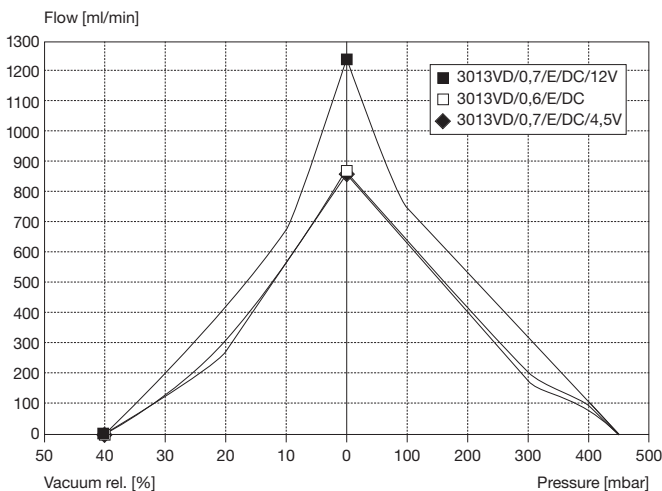

Option

Motor	BLDC motor
Bearing type	Ball bearing

Model key: 3013... Stock programme

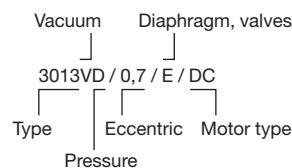

The information presented in this material is based on technical data and test results of nominal units. It is believed to be accurate and reliable and is offered as an aid to help in the selection of Thomas products. It is the responsibility of the user to determine the suitability of the product for the intended use and the user assumes all risk and liability whatsoever in connection therewith. Thomas does not warrant, guarantee or assume any obligation or liability in connection with this information.

Diaphragm Pump 3013 VD LC

Flow	1,3 l/min
Max. pressure	600 mbar
Max. vacuum	45%

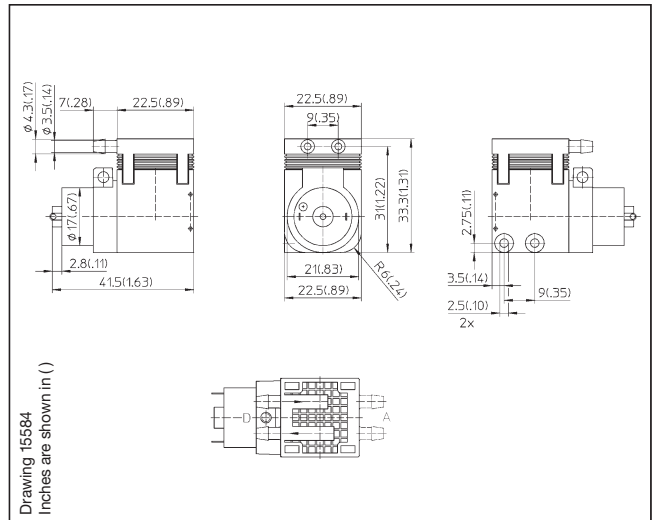

Pneumatic Data

Description	3013VD/0,8/E/LC	3013VD/0,7/E/LC	3013VD/0,7/E/LC
Part number	3,0 V 4,5 V 12,0 V 30130039	30130002	30130003
Max. flow	0,9 l/min	0,9 l/min	1,3 l/min
Max. intermittent duty	600 mbar	450 mbar	450 mbar
Max. continuous pressure	200 mbar	200 mbar	200 mbar
Max. restart pressure	200 mbar	200 mbar	200 mbar
Max. vacuum	45%	40%	40%
Max. restart vacuum	20%	20%	20%

Electrical Data

Motor type	Permanent magnet	Permanent magnet	Permanent magnet
Rated power	180 mA	120 mA	60 mA
Protection class	IP00	IP00	IP00
Bearing type	Sleeve bearing	Sleeve bearing	Sleeve bearing

General Data

Ambient temperature	10 to 40 °C	10 to 40 °C	10 to 40 °C
Media temperature	10 to 40 °C	10 to 40 °C	10 to 40 °C
Weight	32 g	32 g	32 g
Port direction	D	D	D

Wetted Parts

Wetted Parts	Options
Pump head	Polycarbonate
Diaphragm	EPDM
Valve/gasket	EPDM
	Ryton®
	FPM (Viton®)
	FPM (Viton®)

Flow Curves

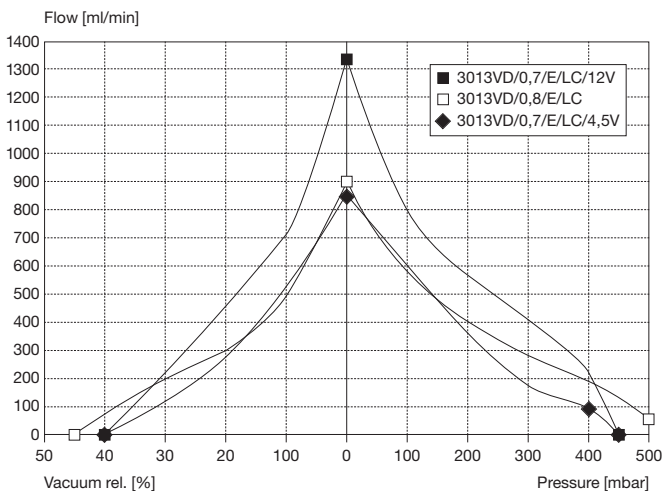

Option

Motor	BLDC motor
Bearing type	Ball bearing

Model key: 3013... Stock programme

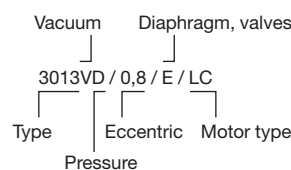

The information presented in this material is based on technical data and test results of nominal units. It is believed to be accurate and reliable and is offered as an aid to help in the selection of Thomas products. It is the responsibility of the user to determine the suitability of the product for the intended use and the user assumes all risk and liability whatsoever in connection therewith. Thomas does not warrant, guarantee or assume any obligation or liability in connection with this information.



Printed in Germany.
Art.-Nr.: 17000075 01/2011
ClimatePartner 
printed climate-neutrally

Gardner Denver Thomas GmbH
Benzstraße 28 · Gewerbegebiet Nord · D-82178 Puchheim
Phone: +49 89 80900-0 · Fax: +49 89 808368
e-Mail: thomas.de@gardnerdenver.com · <http://www.gd-thomas.com>